



# Dimensional Drawing

SNC Models

01/15/2005

SNC-8-XX-300; SNC-8-XX-400

## Pump Dimensions

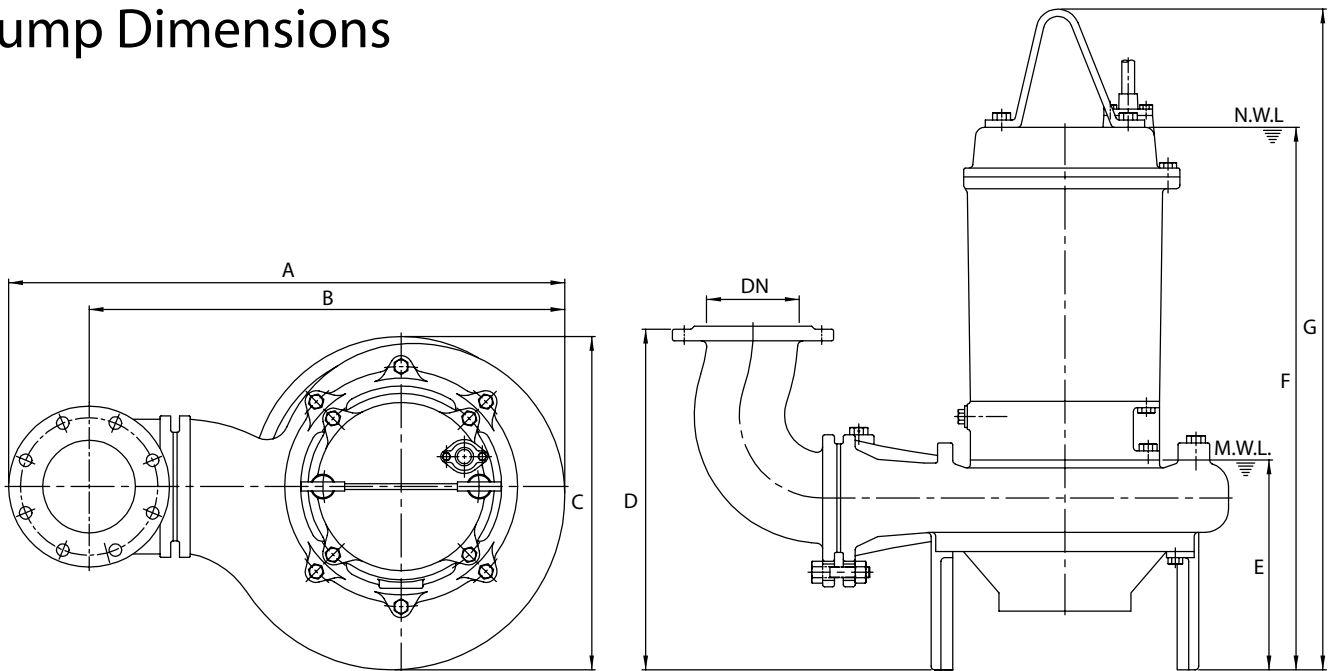

TYPE	DN	A	B	C	D	E	F	G
SNC-8-XX-300	8	35.25	28.75	18.88	16.25	11.25	33.38	39.25
SNC-8-XX-400	8	36.63	30.25	20.13	16.38	11.25	37.50	43.38

N.W.L.: Normal water level

M.W.L.: Minimum water level

## Easy Lift GRS - Guide Rail System Dimensions

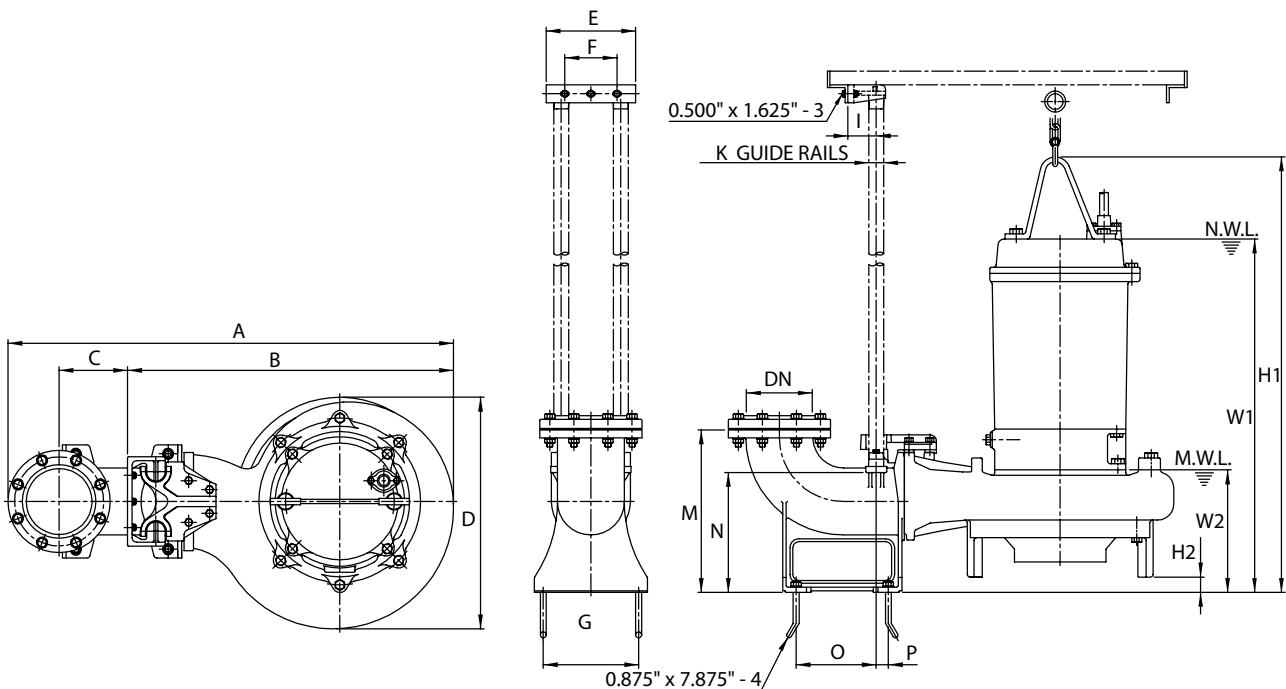

TYPE	DN	A	B	C	D	E	F	G	I	K	M	N	O	P	W1	W2	H1	H2
SNC-8-XX-300	8	48.38	32.50	9.00	18.88	11.75	6.88	12.63	3.75	2.00	21.50	16.63	11.63	1.63	33.75	11.25	39.63	0.38
SNC-8-XX-400	8	49.75	33.88	9.00	20.13	11.75	6.88	12.63	3.75	2.00	21.50	16.63	11.63	1.63	37.88	11.25	43.75	0.38

All dimensions are in inches unless otherwise noted.